

Sub MW

E-44, E-48, E-53

MW

E-70, E-82 E2, E-82 E4,
E-92, E-101, E-101 E2,
E-115, E-126 EP4

Multi-MW

E-126

The most suitable wind energy converter for every location

ENERCON product overview

ENERCON wind energy converters – Advantage through innovation.

For more than 25 years, ENERCON wind energy converters have been synonymous with technological progress and high profitability. The importance of technologies contributing to power supply security is constantly increasing. ENERCON's control systems offer a wide range of technological options which can be adapted to the grid parameters of large power transmission systems. Continuous research and development, as well as a degree of vertical integration that is unrivalled in the industry, ensure the high quality standards, the reliability and the profitability of ENERCON wind energy converters. Together with customer-oriented service, they guarantee the company's continued success.



Calculated power curve

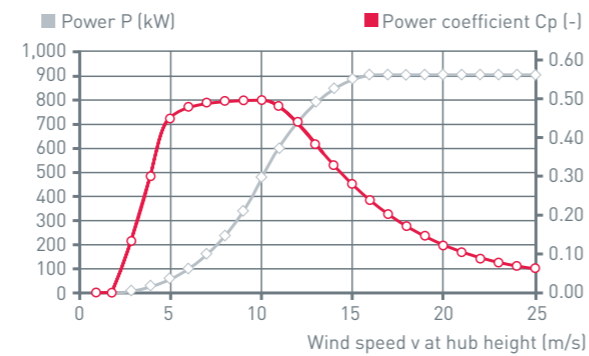

Wind (m/s)	Power P (kW)	Power-coefficient Cp (-)
1	0.0	0.00
2	0.0	0.00
3	4.0	0.16
4	20.0	0.34
5	50.0	0.43
6	96.0	0.48
7	156.0	0.49
8	238.0	0.50
9	340.0	0.50
10	466.0	0.50
11	600.0	0.48
12	710.0	0.44
13	790.0	0.39
14	850.0	0.33
15	880.0	0.28
16	905.0	0.24
17	910.0	0.20
18	910.0	0.17
19	910.0	0.14
20	910.0	0.12
21	910.0	0.11
22	910.0	0.09
23	910.0	0.08
24	910.0	0.07
25	910.0	0.06

$\rho = 1.225 \text{ kg/m}^3$

Technical specifications E-44

Rated power:	900 kW
Rotor diameter:	44 m
Hub height in meter:	45 / 55
Wind zone (DIBt):	-
Wind class (IEC):	IEC/EN IA
WEC concept:	Gearless, variable speed, single blade adjustment
Rotor	
Type:	Upwind rotor with active pitch control
Rotational direction:	Clockwise
No. of blades:	3
Swept area:	1,521 m ²
Blade material:	GRP (epoxy resin); Built-in lightning protection
Rotational speed:	Variable, 16 - 34.5 rpm
Pitch control:	ENERCON single blade pitch system; one independent pitch system per rotor blade with allocated emergency supply
Drive train with generator	
Main bearing:	Twin tapered roller bearing
Generator:	ENERCON direct-drive annular generator
Grid feed:	ENERCON inverter
Brake systems:	- 3 independent pitch control systems with emergency power supply - Rotor brake - Rotor lock
Yaw system:	Active via yaw gear, load-dependent damping
Cut-out wind speed:	28 - 34 m/s (with ENERCON storm control*)
Remote monitoring:	ENERCON SCADA

* For more information on the ENERCON storm control feature, please see the last page.

E-44

900 kW

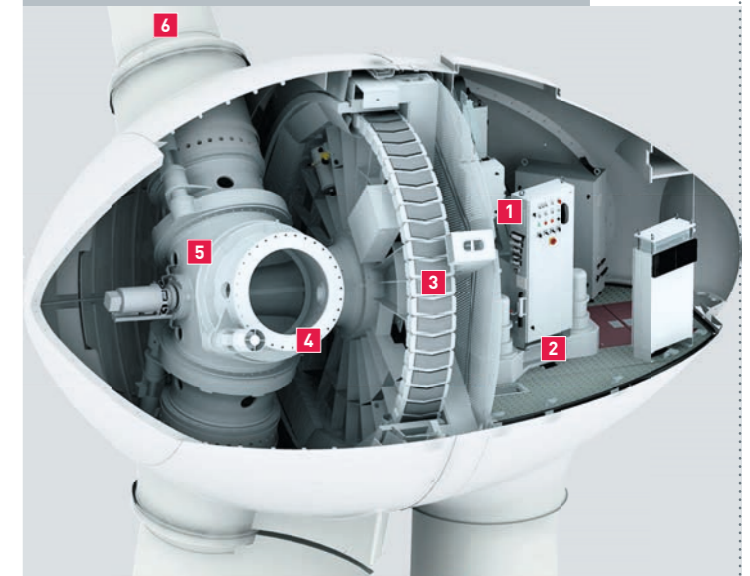

- 1 Main carrier
- 2 Yaw drive
- 3 Annular generator
- 4 Blade adapter
- 5 Rotor hub
- 6 Rotor blade



Calculated power curve

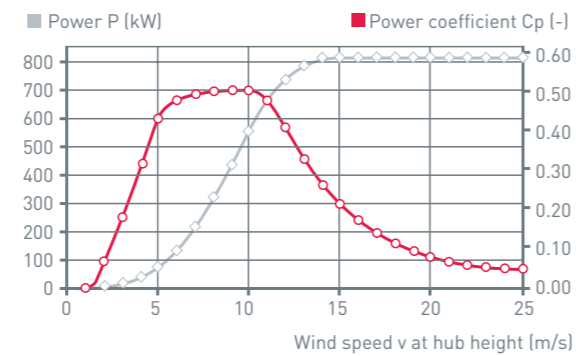

Wind (m/s)	Power P (kW)	Power-coefficient Cp (-)
1	0.0	0.00
2	0.0	0.00
3	5.0	0.17
4	25.0	0.35
5	60.0	0.43
6	110.0	0.46
7	180.0	0.47
8	275.0	0.48
9	400.0	0.50
10	555.0	0.50
11	671.0	0.45
12	750.0	0.39
13	790.0	0.32
14	810.0	0.27
15	810.0	0.22
16	810.0	0.18
17	810.0	0.15
18	810.0	0.13
19	810.0	0.11
20	810.0	0.09
21	810.0	0.08
22	810.0	0.07
23	810.0	0.06
24	810.0	0.05
25	810.0	0.05

$\rho = 1.225 \text{ kg/m}^3$

Technical specifications E-48

Rated power:	800 kW
Rotor diameter:	48 m
Hub height in meter:	50 / 60 / 65 / 76
Wind zone (DIBt):	WZ III
Wind class (IEC):	IEC/EN IIA
WEC concept:	Gearless, variable speed, single blade adjustment
Rotor	
Type:	Upwind rotor with active pitch control
Rotational direction:	Clockwise
No. of blades:	3
Swept area:	1,810 m ²
Blade material:	GRP (epoxy resin); Built-in lightning protection
Rotational speed:	Variable, 16 - 31.5 rpm
Pitch control:	ENERCON single blade pitch system; one independent pitch system per rotor blade with allocated emergency supply
Drive train with generator	
Main bearing:	Twin tapered roller bearing
Generator:	ENERCON direct-drive annular generator
Grid feed:	ENERCON inverter
Brake systems:	- 3 independent pitch control systems with emergency power supply - Rotor brake - Rotor lock
Yaw system:	Active via yaw gear, load-dependent damping
Cut-out wind speed:	28 - 34 m/s (with ENERCON storm control*)
Remote monitoring:	ENERCON SCADA

* For more information on the ENERCON storm control feature, please see the last page.

E-48

800 kW

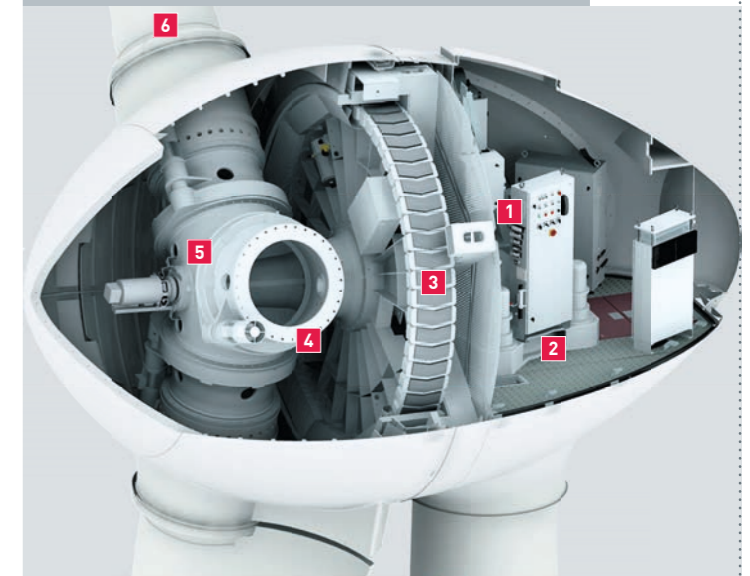

- 1 Main carrier
- 2 Yaw drive
- 3 Annular generator
- 4 Blade adapter
- 5 Rotor hub
- 6 Rotor blade



Calculated power curve

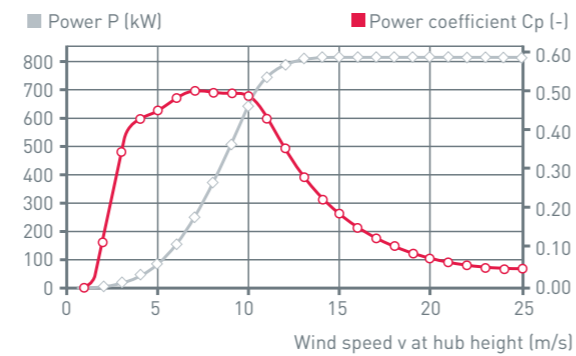

Wind (m/s)	Power P (kW)	Power-coefficient Cp (-)
1	0.0	0.00
2	2.0	0.19
3	14.0	0.39
4	38.0	0.44
5	77.0	0.46
6	141.0	0.48
7	228.0	0.49
8	336.0	0.49
9	480.0	0.49
10	645.0	0.48
11	744.0	0.42
12	780.0	0.34
13	810.0	0.27
14	810.0	0.22
15	810.0	0.18
16	810.0	0.15
17	810.0	0.12
18	810.0	0.10
19	810.0	0.09
20	810.0	0.08
21	810.0	0.06
22	810.0	0.06
23	810.0	0.05
24	810.0	0.04
25	810.0	0.04

$\rho = 1.225 \text{ kg/m}^3$

Technical specifications E-53

Rated power:	800 kW
Rotor diameter:	52.9 m
Hub height in meter:	50 / 60 / 73
Wind zone (DIBt):	WZ II exp
Wind class (IEC):	IEC/NVN Class S ($V_{av} = 7.5 \text{ m/s}$, $V_{ext} = 57 \text{ m/s}$)
WEC concept:	Gearless, variable speed, single blade adjustment
Rotor	
Type:	Upwind rotor with active pitch control
Rotational direction:	Clockwise
No. of blades:	3
Swept area:	2,198 m ²
Blade material:	GRP (epoxy resin); Built-in lightning protection
Rotational speed:	Variable, 11 - 29.5 rpm
Pitch control:	ENERCON single blade pitch system; one independent pitch system per rotor blade with allocated emergency supply
Drive train with generator	
Main bearing:	Twin tapered roller bearing
Generator:	ENERCON direct-drive annular generator
Grid feed:	ENERCON inverter
Brake systems:	- 3 independent pitch control systems with emergency power supply - Rotor brake - Rotor lock
Yaw system:	Active via yaw gear, load-dependent damping
Cut-out wind speed:	28 - 34 m/s (with ENERCON storm control*)
Remote monitoring:	ENERCON SCADA

* For more information on the ENERCON storm control feature, please see the last page.

E-53

800 kW

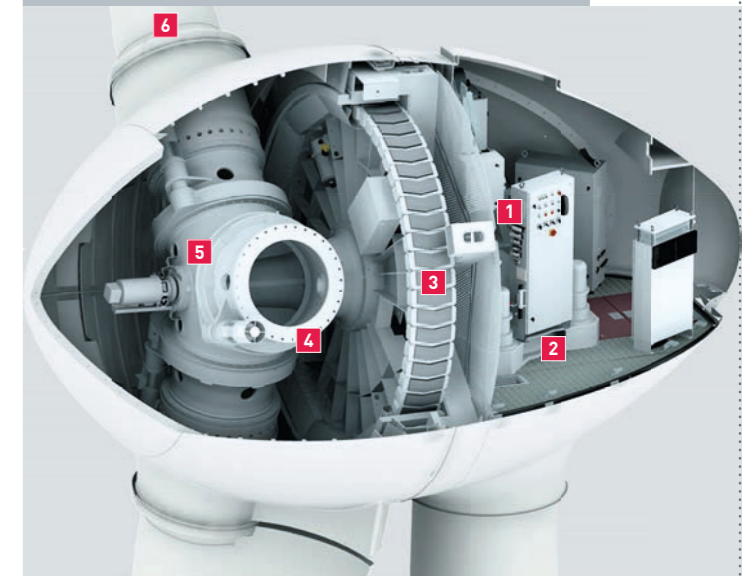

- 1 Main carrier
- 2 Yaw drive
- 3 Annular generator
- 4 Blade adapter
- 5 Rotor hub
- 6 Rotor blade



Calculated power curve

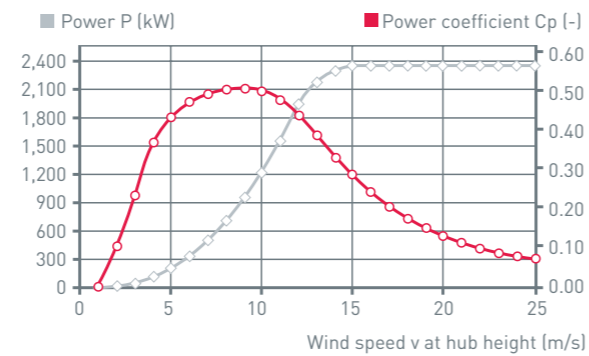

Wind (m/s)	Power P (kW)	Power-coefficient Cp (-)
1	0.0	0.00
2	2.0	0.10
3	18.0	0.27
4	56.0	0.36
5	127.0	0.42
6	240.0	0.46
7	400.0	0.48
8	626.0	0.50
9	892.0	0.50
10	1,223.0	0.50
11	1,590.0	0.49
12	1,900.0	0.45
13	2,080.0	0.39
14	2,230.0	0.34
15	2,300.0	0.28
16	2,310.0	0.23
17	2,310.0	0.19
18	2,310.0	0.16
19	2,310.0	0.14
20	2,310.0	0.12
21	2,310.0	0.10
22	2,310.0	0.09
23	2,310.0	0.08
24	2,310.0	0.07
25	2,310.0	0.06

p = 1.225 kg/m³

Technical specifications E-70 E4

Rated power:	2,300 kW
Rotor diameter:	71 m
Hub height in meter:	57 / 64 / 75 / 85 / 98 / 114
Wind zone (DIBt):	WZ III
Wind class (IEC):	IEC/EN IA and IEC/EN IIA
WEC concept:	Gearless, variable speed, single blade adjustment
Rotor	
Type:	Upwind rotor with active pitch control
Rotational direction:	Clockwise
No. of blades:	3
Swept area:	3,959 m ²
Blade material:	GRP (epoxy resin); Built-in lightning protection
Rotational speed:	Variable, 6 - 21 rpm
Pitch control:	ENERCON single blade pitch system; one inde- pendent pitch system per rotor blade with allocated emergency supply

Drive train with generator

Main bearing:	Double row tapered/cylin- drical roller bearings
Generator:	ENERCON direct-drive annular generator
Grid feed:	ENERCON inverter
Brake systems:	- 3 independent pitch control systems with emer- gency power supply - Rotor brake - Rotor lock
Yaw system:	Active via yaw gear, load-dependent damping
Cut-out wind speed:	28 - 34 m/s (with ENERCON storm control*)
Remote monitoring:	ENERCON SCADA

* For more information on the ENERCON storm control feature,
please see the last page.

E-70

2,300 kW

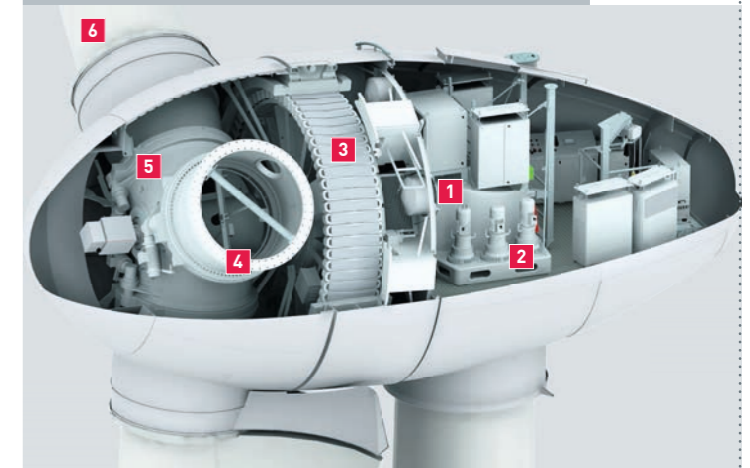

- 1 Main carrier
- 2 Yaw drive
- 3 Annular generator
- 4 Blade adapter
- 5 Rotor hub
- 6 Rotor blade



Calculated power curve

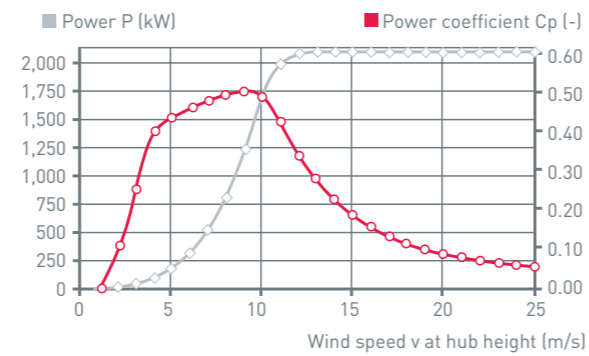

Wind (m/s)	Power P (kW)	Power-coefficient Cp (-)
1	0.0	0.00
2	3.0	0.12
3	25.0	0.29
4	82.0	0.40
5	174.0	0.43
6	321.0	0.46
7	532.0	0.48
8	815.0	0.49
9	1,180.0	0.50
10	1,580.0	0.49
11	1,810.0	0.42
12	1,980.0	0.35
13	2,050.0	0.29
14	2,050.0	0.23
15	2,050.0	0.19
16	2,050.0	0.15
17	2,050.0	0.13
18	2,050.0	0.11
19	2,050.0	0.09
20	2,050.0	0.08
21	2,050.0	0.07
22	2,050.0	0.06
23	2,050.0	0.05
24	2,050.0	0.05
25	2,050.0	0.04

$\rho = 1.225 \text{ kg/m}^3$

Technical specifications E-82 E2

Rated power:	2,000 kW
Rotor diameter:	82 m
Hub height in meter:	78 / 84 / 85 / 98 / 108 / 138
Wind zone (DIBt):	WZ III
Wind class (IEC):	IEC/EN IIA
WEC concept:	Gearless, variable speed, single blade adjustment
Rotor	
Type:	Upwind rotor with active pitch control
Rotational direction:	Clockwise
No. of blades:	3
Swept area:	5,281 m ²
Blade material:	GRP (epoxy resin); Built-in lightning protection
Rotational speed:	Variable, 6 - 18 rpm
Pitch control:	ENERCON single blade pitch system; one inde- pendent pitch system per rotor blade with allocated emergency supply

Drive train with generator

Main bearing:	Double row tapered/cylin- drical roller bearings
Generator:	ENERCON direct-drive annular generator
Grid feed:	ENERCON inverter
Brake systems:	- 3 independent pitch control systems with emer- gency power supply - Rotor brake - Rotor lock
Yaw system:	Active via yaw gear, load-dependent damping
Cut-out wind speed:	28 - 34 m/s (with ENERCON storm control*)
Remote monitoring:	ENERCON SCADA

* For more information on the ENERCON storm control feature,
please see the last page.

E-82

2,000 kW

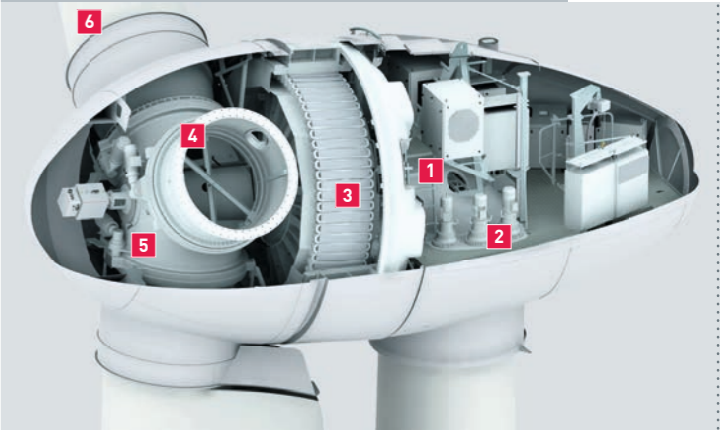

- 1 Main carrier
- 2 Yaw drive
- 3 Annular generator
- 4 Blade adapter
- 5 Rotor hub
- 6 Rotor blade



Calculated power curve

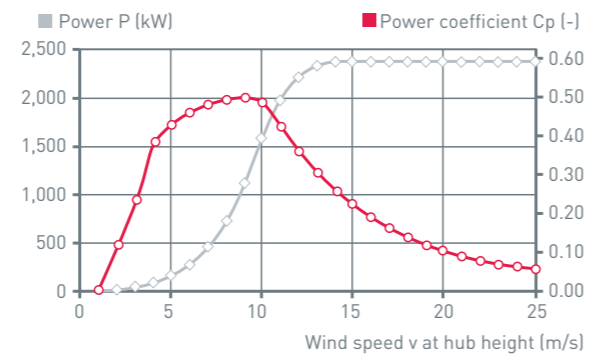

Wind (m/s)	Power P (kW)	Power-coefficient Cp (-)
1	0.0	0.00
2	3.0	0.12
3	25.0	0.29
4	82.0	0.40
5	174.0	0.43
6	321.0	0.46
7	532.0	0.48
8	815.0	0.49
9	1,180.0	0.50
10	1,580.0	0.49
11	1,890.0	0.44
12	2,100.0	0.38
13	2,250.0	0.32
14	2,350.0	0.26
15	2,350.0	0.22
16	2,350.0	0.18
17	2,350.0	0.15
18	2,350.0	0.12
19	2,350.0	0.11
20	2,350.0	0.09
21	2,350.0	0.08
22	2,350.0	0.07
23	2,350.0	0.06
24	2,350.0	0.05
25	2,350.0	0.05

$\rho = 1.225 \text{ kg/m}^3$

Technical specifications E-82 E2

Rated power: 2,300 kW
Rotor diameter: 82 m
Hub height in meter: 78 / 84 / 85 / 98 / 108 / 138
Wind zone (DIBt): WZ III
Wind class (IEC): IEC/EN IIA

WEC concept: Gearless, variable speed, single blade adjustment

Rotor

Type: Upwind rotor with active pitch control
Rotational direction: Clockwise
No. of blades: 3
Swept area: 5,281 m²
Blade material: GRP (epoxy resin); Built-in lightning protection
Rotational speed: Variable, 6 - 18 rpm
Pitch control: ENERCON single blade pitch system; one independent pitch system per rotor blade with allocated emergency supply

Drive train with generator

Main bearing: Double row tapered/cylindrical roller bearings
Generator: ENERCON direct-drive annular generator

Grid feed: ENERCON inverter

Brake systems: - 3 independent pitch control systems with emergency power supply
 - Rotor brake
 - Rotor lock

Yaw system: Active via yaw gear, load-dependent damping

Cut-out wind speed: 28 - 34 m/s (with ENERCON storm control*)

Remote monitoring: ENERCON SCADA

* For more information on the ENERCON storm control feature, please see the last page.

E-82

2,300 kW

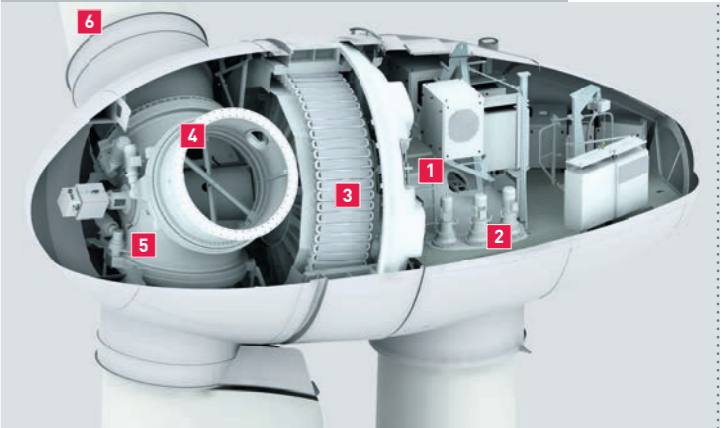

- 1 Main carrier
- 2 Yaw drive
- 3 Annular generator
- 4 Blade adapter
- 5 Rotor hub
- 6 Rotor blade



Calculated power curve

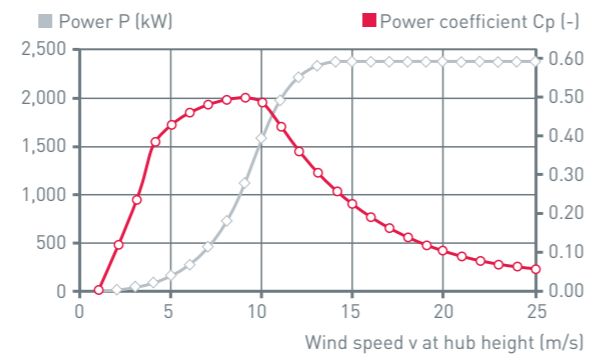

Wind (m/s)	Power P (kW)	Power-coefficient Cp (-)
1	0.0	0.00
2	3.0	0.12
3	25.0	0.29
4	82.0	0.40
5	174.0	0.43
6	321.0	0.46
7	532.0	0.48
8	815.0	0.49
9	1,180.0	0.50
10	1,580.0	0.49
11	1,890.0	0.44
12	2,100.0	0.38
13	2,250.0	0.32
14	2,350.0	0.26
15	2,350.0	0.22
16	2,350.0	0.18
17	2,350.0	0.15
18	2,350.0	0.12
19	2,350.0	0.11
20	2,350.0	0.09
21	2,350.0	0.08
22	2,350.0	0.07
23	2,350.0	0.06
24	2,350.0	0.05
25	2,350.0	0.05

$\rho = 1.225 \text{ kg/m}^3$

Technical specifications E-82 E4

Rated power:	2,350 kW
Rotor diameter:	82 m
Hub height in meter:	59 / 69 / 78 / 84
Wind zone (DIBt):	-
Wind class (IEC):	IEC/EN IA and IEC/EN IIA
WEC concept:	Gearless, variable speed, single blade adjustment
Rotor	
Type:	Upwind rotor with active pitch control
Rotational direction:	Clockwise
No. of blades:	3
Swept area:	5,281 m ²
Blade material:	GRP (epoxy resin); Built-in lightning protection
Rotational speed:	Variable, 6 - 18 rpm
Pitch control:	ENERCON single blade pitch system; one independent pitch system per rotor blade with allocated emergency supply

Drive train with generator

Main bearing:	Double row tapered/cylindrical roller bearings
Generator:	ENERCON direct-drive annular generator
Grid feed:	ENERCON inverter
Brake systems:	- 3 independent pitch control systems with emergency power supply - Rotor brake - Rotor lock

Yaw system: Active via yaw gear, load-dependent damping

Cut-out wind speed: 28 - 34 m/s (with ENERCON storm control*)

Remote monitoring: ENERCON SCADA

* For more information on the ENERCON storm control feature, please see the last page.

E-82

2,350 kW

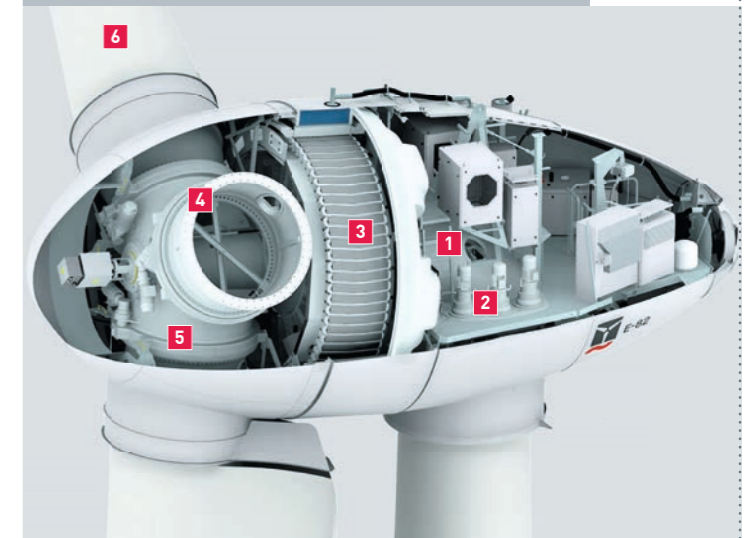

- 1 Main carrier
- 2 Yaw drive
- 3 Annular generator
- 4 Blade adapter
- 5 Rotor hub
- 6 Rotor blade



Calculated power curve

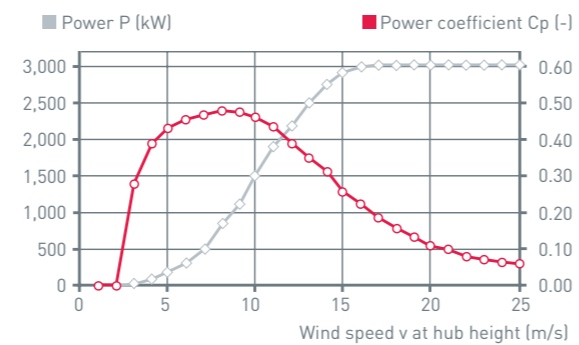

Wind (m/s)	Power P (kW)	Power-coefficient Cp (-)
1	0.0	0.000
2	0.0	0.000
3	25.0	0.286
4	82.0	0.396
5	174.0	0.430
6	321.0	0.459
7	525.0	0.473
8	800.0	0.483
9	1,135.0	0.481
10	1,510.0	0.467
11	1,880.0	0.437
12	2,200.0	0.394
13	2,500.0	0.352
14	2,770.0	0.312
15	2,910.0	0.267
16	3,000.0	0.226
17	3,020.0	0.190
18	3,020.0	0.160
19	3,020.0	0.136
20	3,020.0	0.117
21	3,020.0	0.101
22	3,020.0	0.088
23	3,020.0	0.077
24	3,020.0	0.068
25	3,020.0	0.060

p = 1,225 kg/m³

Technical specifications E-82 E4

Rated power:	3,000 kW
Rotor diameter:	82 m
Hub height in meter:	69 / 78 / 84
Wind zone (DIBt):	-
Wind class (IEC):	IEC/EN IA and IEC/EN IIA
WEC concept:	Gearless, variable speed, single blade adjustment

Rotor

Type:	Upwind rotor with active pitch control
Rotational direction:	Clockwise
No. of blades:	3
Swept area:	5,281 m ²
Blade material:	GRP (epoxy resin); Built-in lightning protection
Rotational speed:	Variable, 6 - 18 rpm
Pitch control:	ENERCON single blade pitch system; one independent pitch system per rotor blade with allocated emergency supply

Drive train with generator

Main bearing:	Double row tapered/cylindrical roller bearings
Generator:	ENERCON direct-drive annular generator

Grid feed: ENERCON inverter

Brake systems:	- 3 independent pitch control systems with emergency power supply - Rotor brake - Rotor lock
-----------------------	--

Yaw system: Active via yaw gear, load-dependent damping**Cut-out wind speed:** 28 - 34 m/s (with ENERCON storm control*)**Remote monitoring:** ENERCON SCADA

* For more information on the ENERCON storm control feature, please see the last page.

E-82

3,000 kW

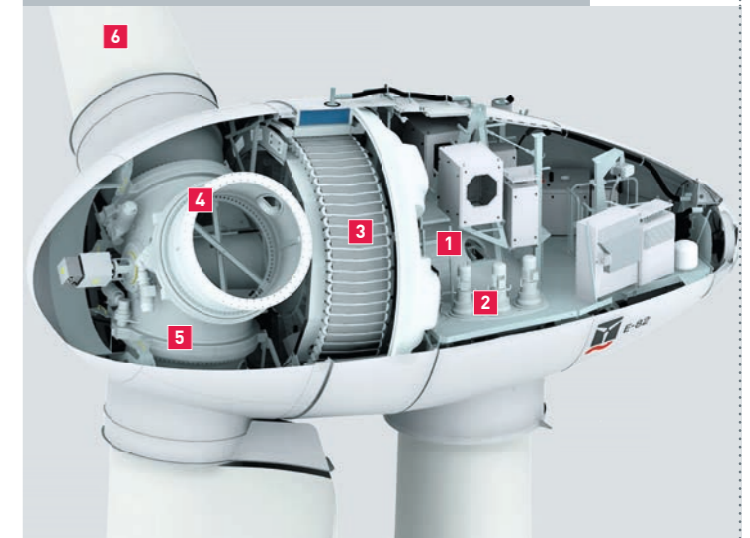

- 1 Main carrier
- 2 Yaw drive
- 3 Annular generator
- 4 Blade adapter
- 5 Rotor hub
- 6 Rotor blade



Calculated power curve

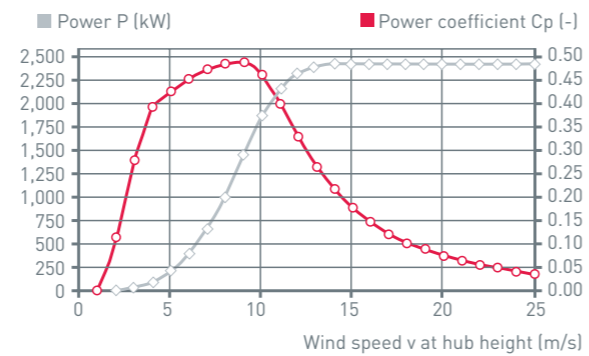

Wind (m/s)	Power P (kW)	Power-coefficient Cp (-)
1	0.0	0.00
2	3.6	0.11
3	29.9	0.27
4	98.2	0.38
5	208.3	0.41
6	384.3	0.44
7	637.0	0.46
8	975.8	0.47
9	1,403.6	0.47
10	1,817.8	0.45
11	2,088.7	0.39
12	2,237.0	0.32
13	2,300.0	0.26
14	2,350.0	0.21
15	2,350.0	0.17
16	2,350.0	0.14
17	2,350.0	0.12
18	2,350.0	0.10
19	2,350.0	0.08
20	2,350.0	0.07
21	2,350.0	0.06
22	2,350.0	0.05
23	2,350.0	0.05
24	2,350.0	0.04
25	2,350.0	0.04

$\rho = 1.225 \text{ kg/m}^3$

Technical specifications E-92

Rated power: 2,350 kW
Rotor diameter: 92 m
Hub height in meter: 78 / 84 / 85 / 98 / 104 / 108 / 138
Wind zone (DIBt): WZ III
Wind class (IEC): IEC/EN IIA
WEC concept: Gearless, variable speed, single blade adjustment

Rotor
 Type: Upwind rotor with active pitch control
 Rotational direction: Clockwise
 No. of blades: 3
 Swept area: 6,648 m²
 Blade material: GRP (epoxy resin); Built-in lightning protection
 Rotational speed: Variable, 5 - 16 rpm
 Pitch control: ENERCON single blade pitch system; one independent pitch system per rotor blade with allocated emergency supply

Drive train with generator
 Main bearing: Double row tapered/cylindrical roller bearings
 Generator: ENERCON direct-drive annular generator
Grid feed: ENERCON inverter
Brake systems: - 3 independent pitch control systems with emergency power supply
 - Rotor brake
 - Rotor lock

Yaw system: Active via yaw gear, load-dependent damping

Cut-out wind speed: 28 - 34 m/s (with ENERCON storm control*)

Remote monitoring: ENERCON SCADA

* For more information on the ENERCON storm control feature, please see the last page.

E-92

2,350 kW

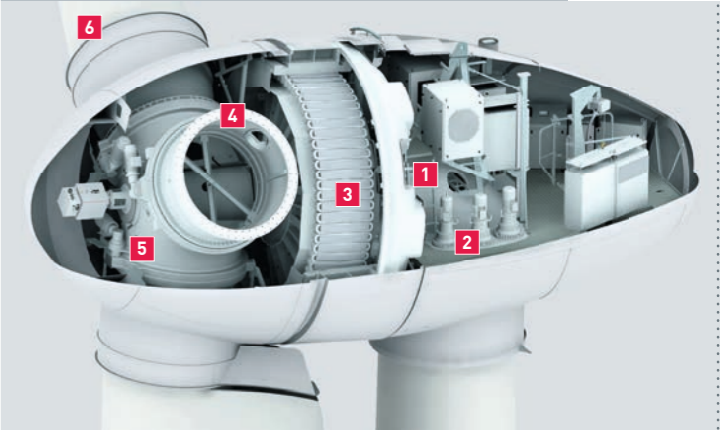

- 1 Main carrier
- 2 Yaw drive
- 3 Annular generator
- 4 Blade adapter
- 5 Rotor hub
- 6 Rotor blade



Calculated power curve

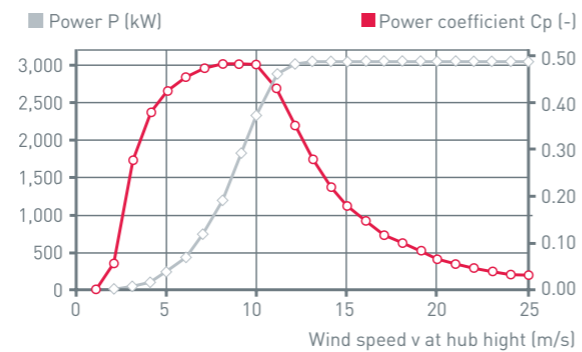

Wind (m/s)	Power P (kW)	Power-coefficient Cp (-)
1	0.0	0.00
2	3.0	0.076
3	37.0	0.279
4	118.0	0.376
5	258.0	0.421
6	479.0	0.452
7	790.0	0.469
8	1,200.0	0.478
9	1,710.0	0.478
10	2,340.0	0.477
11	2,867.0	0.439
12	3,034.0	0.358
13	3,050.0	0.283
14	3,050.0	0.227
15	3,050.0	0.184
16	3,050.0	0.152
17	3,050.0	0.127
18	3,050.0	0.107
19	3,050.0	0.091
20	3,050.0	0.078
21	3,050.0	0.067
22	3,050.0	0.058
23	3,050.0	0.051
24	3,050.0	0.045
25	3,050.0	0.040

$\rho = 1.225 \text{ kg/m}^3$

Technical specifications E-101

Rated power:	3,050 kW
Rotor diameter:	101 m
Hub height in meter:	99 / 124 / 135 / 149
Wind zone (DIBt):	WZ III
Wind class (IEC):	IEC/EN IIA
WEC concept:	Gearless, variable speed, single blade adjustment
Rotor	
Type:	Upwind rotor with active pitch control
Rotational direction:	Clockwise
No. of blades:	3
Swept area:	8,012 m ²
Blade material:	GRP (epoxy resin); Built-in lightning protection
Rotational speed:	Variable, 4 - 14.5 rpm
Pitch control:	ENERCON single blade pitch system; one independent pitch system per rotor blade with allocated emergency supply
Drive train with generator	
Main bearing:	Double row tapered/cylindrical roller bearings
Generator:	ENERCON direct-drive annular generator
Grid feed:	ENERCON inverter
Brake systems:	- 3 independent pitch control systems with emergency power supply - Rotor brake - Rotor lock, latching (10°)
Yaw system:	Active via yaw gear, load-dependent damping
Cut-out wind speed:	28 - 34 m/s (with ENERCON storm control*)
Remote monitoring:	ENERCON SCADA

* For more information on the ENERCON storm control feature, please see the last page.

E-101

3,050 kW

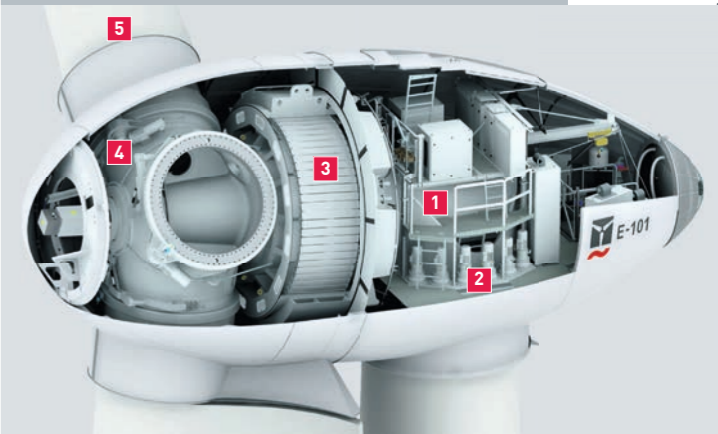

- 1 Main carrier
- 2 Yaw drive
- 3 Annular generator
- 4 Rotor hub
- 5 Rotor blade



Calculated power curve

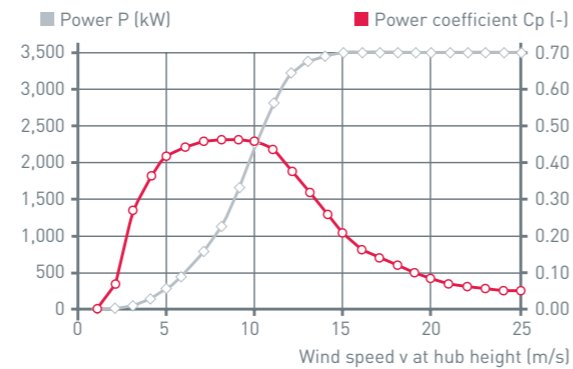

Wind (m/s)	Power P (kW)	Power-coefficient Cp (-)
1	0.0	0.00
2	3.0	0.08
3	37.0	0.28
4	116.0	0.37
5	253.0	0.41
6	469.0	0.44
7	775.0	0.46
8	1,175.0	0.47
9	1,680.0	0.47
10	2,280.0	0.46
11	2,810.0	0.43
12	3,200.0	0.38
13	3,400.0	0.32
14	3,465.0	0.26
15	3,500.0	0.21
16	3,500.0	0.17
17	3,500.0	0.15
18	3,500.0	0.12
19	3,500.0	0.10
20	3,500.0	0.09
21	3,500.0	0.08
22	3,500.0	0.07
23	3,500.0	0.06
24	3,500.0	0.05
25	3,500.0	0.05

p = 1.225 kg/m³

Technical specifications E-101 E2

Rated power:	3,500 kW
Rotor diameter:	101 m
Hub height in meter:	74
Wind zone (DIBt):	WZ IV
Wind class (IEC):	IEC/EN IA
WEC concept:	Gearless, variable speed, single blade adjustment
Rotor	
Type:	Upwind rotor with active pitch control
Rotational direction:	Clockwise
No. of blades:	3
Swept area:	8,012 m ²
Blade material:	GRP (epoxy resin); Built-in lightning protection
Rotational speed:	Variable, 4 - 14.5 rpm
Pitch control:	ENERCON single blade pitch system; one independent pitch system per rotor blade with allocated emergency supply
Drive train with generator	
Main bearing:	Double row tapered/cylindrical roller bearings
Generator:	ENERCON direct-drive annular generator
Grid feed:	ENERCON inverter
Brake systems:	- 3 independent pitch control systems with emergency power supply - Rotor brake - Rotor lock, latching (10°)
Yaw system:	Active via yaw gear, load-dependent damping
Cut-out wind speed:	28 - 34 m/s (with ENERCON storm control*)
Remote monitoring:	ENERCON SCADA

* For more information on the ENERCON storm control feature, please see the last page.

E-101

3,500 kW

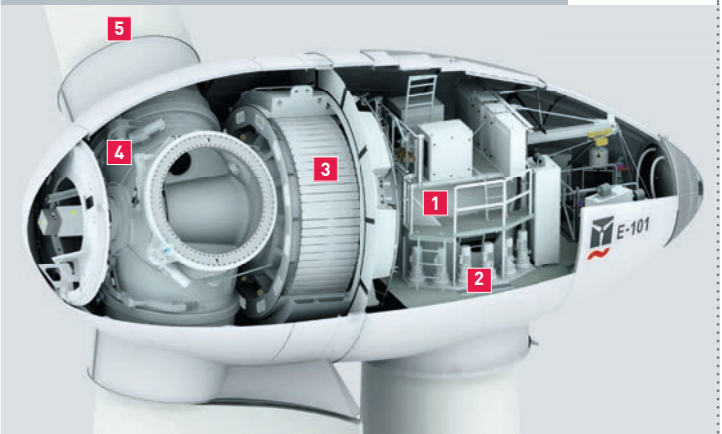

- 1 Main carrier
- 2 Yaw drive
- 3 Annular generator
- 4 Rotor hub
- 5 Rotor blade



Calculated power curve

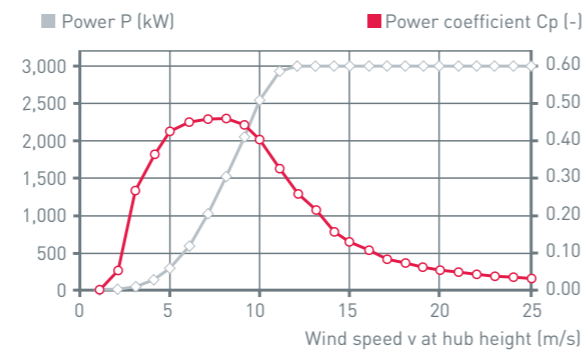

Wind (m/s)	Power P (kW)	Power-coefficient Cp [-]
1	0.0	0.00
2	3.0	0.058
3	48.5	0.279
4	155.0	0.376
5	339.0	0.421
6	627.5	0.451
7	1,035.5	0.469
8	1,549.0	0.470
9	2,090.0	0.445
10	2,580.0	0.401
11	2,900.0	0.338
12	3,000.0	0.270
13	3,000.0	0.212
14	3,000.0	0.170
15	3,000.0	0.138
16	3,000.0	0.114
17	3,000.0	0.095
18	3,000.0	0.080
19	3,000.0	0.068
20	3,000.0	0.058
21	3,000.0	0.050
22	3,000.0	0.044
23	3,000.0	0.038
24	3,000.0	0.034
25	3,000.0	0.030

$p = 1.225 \text{ kg/m}^3$

Technical specifications E-115

Rated power:	3,000 kW
Rotor diameter:	115.7 m
Hub height in meter:	92 / 122 / 135 / 149
Wind zone (DIBt):	WZ III
Wind class (IEC):	IEC/EN IIA
WEC concept:	Gearless, variable speed, single blade adjustment
Rotor	
Type:	Upwind rotor with active pitch control
Rotational direction:	Clockwise
No. of blades:	3
Swept area:	10,515.5 m ²
Blade material:	GRP (epoxy resin); Built-in lightning protection
Rotational speed:	Variable, 4 - 12.8 rpm
Pitch control:	ENERCON single blade pitch system; one independent pitch system per rotor blade with allocated emergency supply
Drive train with generator	
Main bearing:	Double row tapered/cylindrical roller bearings
Generator:	ENERCON direct-drive annular generator
Grid feed:	ENERCON inverter
Brake systems:	- 3 independent pitch control systems with emergency power supply - Rotor brake - Rotor lock, latching (10°)
Yaw system:	Active via yaw gear, load-dependent damping
Cut-out wind speed:	28 - 34 m/s (with ENERCON storm control*)
Remote monitoring:	ENERCON SCADA

* For more information on the ENERCON storm control feature, please see the last page.

E-115

3,000 kW

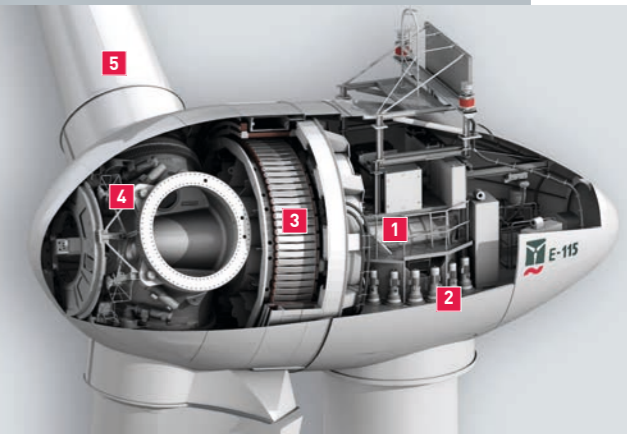

- 1 Main carrier
- 2 Yaw drive
- 3 Annular generator
- 4 Rotor hub
- 5 Rotor blade



Calculated power curve

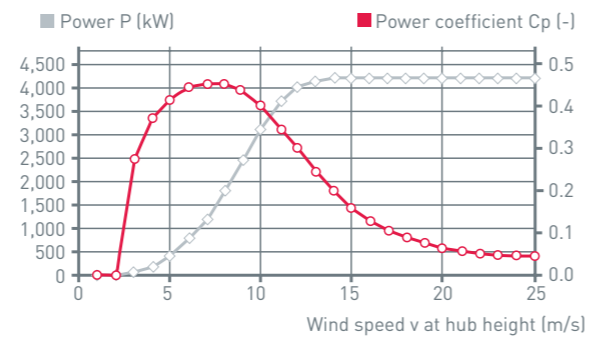

Wind (m/s)	Power P (kW)	Power-coefficient Cp (-)
1	0.0	0.00
2	0.0	0.00
3	58.0	0.28
4	185.0	0.37
5	400.0	0.41
6	745.0	0.44
7	1,200.0	0.45
8	1,790.0	0.45
9	2,450.0	0.43
10	3,120.0	0.40
11	3,660.0	0.35
12	4,000.0	0.30
13	4,150.0	0.24
14	4,200.0	0.20
15	4,200.0	0.16
16	4,200.0	0.13
17	4,200.0	0.11
18	4,200.0	0.09
19	4,200.0	0.08
20	4,200.0	0.07
21	4,200.0	0.06
22	4,200.0	0.05
23	4,200.0	0.04
24	4,200.0	0.04
25	4,200.0	0.03

p = 1,225 kg/m³

Technical specifications E-126 EP4

Rated power:	4,200 kW
Rotor diameter:	127 m
Hub height in meter:	135
Wind zone (DIBt):	WZ III
Wind class (IEC):	IEC/EN IIA
WEC concept:	Gearless, variable speed, single blade adjustment

Rotor

Type:	Upwind rotor with active pitch control
Rotational direction:	Clockwise
No. of blades:	3
Swept area:	12,668 m ²
Blade material:	GRP (epoxy resin); Built-in lightning protection
Rotational speed:	Variable, 3 - 11.6 rpm
Pitch control:	ENERCON single blade pitch system; one independent pitch system per rotor blade with allocated emergency supply

Drive train with generator

Main bearing:	Double row tapered/cylindrical roller bearings
Generator:	ENERCON direct-drive annular generator
Grid feed:	ENERCON inverter
Brake systems:	- 3 independent pitch control systems with emergency power supply - Rotor brake

Yaw system: Active via yaw gear, load-dependent damping

Cut-out wind speed: 28 - 34 m/s (with ENERCON storm control*)

Remote monitoring: ENERCON SCADA

* For more information on the ENERCON storm control feature, please see the last page.

E-126 EP4

4,200 kW

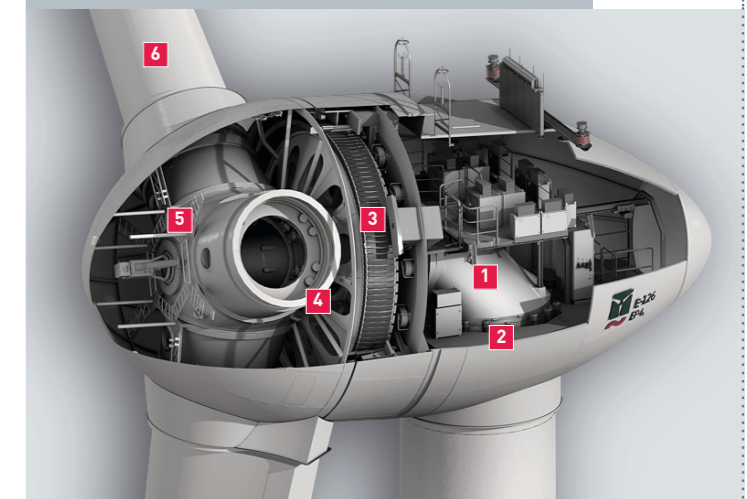

- 1 Main carrier
- 2 Yaw drive
- 3 Annular generator
- 4 Blade adapter
- 5 Rotor hub
- 6 Rotor blade



Calculated power curve

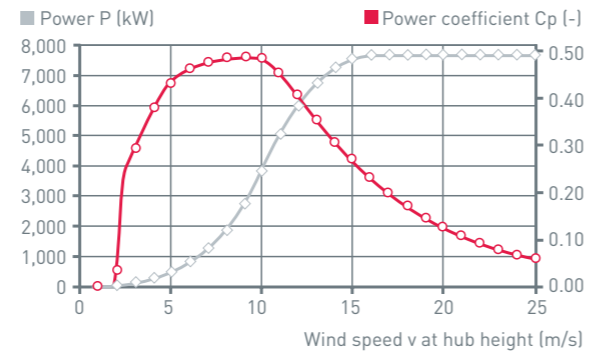

Wind (m/s)	Power P (kW)	Power-coefficient Cp (-)
1	0.0	0.00
2	0.0	0.000
3	55.0	0.263
4	175.0	0.352
5	410.0	0.423
6	760.0	0.453
7	1,250.0	0.470
8	1,900.0	0.478
9	2,700.0	0.477
10	3,750.0	0.483
11	4,850.0	0.470
12	5,750.0	0.429
13	6,500.0	0.381
14	7,000.0	0.329
15	7,350.0	0.281
16	7,500.0	0.236
17	7,580.0	0.199
18	7,580.0	0.168
19	7,580.0	0.142
20	7,580.0	0.122
21	7,580.0	0.105
22	7,580.0	0.092
23	7,580.0	0.080
24	7,580.0	0.071
25	7,580.0	0.063

p = 1.225 kg/m³

Technical specifications E-126

Rated power:	7,580 kW
Rotor diameter:	127 m
Hub height in meter:	135
Wind zone (DIBt):	WZ III
Wind class (IEC):	IEC/EN IA
WEC concept:	Gearless, variable speed, single blade adjustment

Rotor

Type:	Upwind rotor with active pitch control
Rotational direction:	Clockwise
No. of blades:	3
Swept area:	12,668 m ²
Blade material:	GRP (epoxy resin)/GRP; GRP (epoxy resin)/steel; Built-in lightning protection
Rotational speed:	Variable, 5 - 12.1 rpm
Pitch control:	ENERCON single blade pitch system; one independent pitch system per rotor blade with allocated emergency supply

Drive train with generator

Main bearing:	Single row tapered roller bearings
Generator:	ENERCON direct-drive annular generator

Grid feed: ENERCON inverter**Brake systems:** - 3 independent pitch control systems with emergency power supply

- Rotor brake

Yaw system: Active via yaw gear, load-dependent damping**Cut-out wind speed:** 28 - 34 m/s (with ENERCON storm control*)**Remote monitoring:** ENERCON SCADA

* For more information on the ENERCON storm control feature, please see the last page.

E-126

7,580 kW

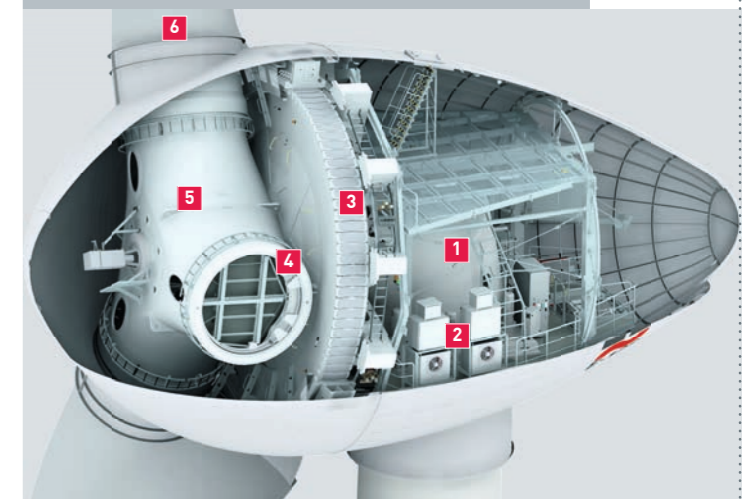

- 1 Main carrier
- 2 Yaw drive
- 3 Annular generator
- 4 Hub adapter
- 5 Rotor hub
- 6 Rotor blade

ENERCON product overview

The product portfolio comprises wind energy converters in the sub- to multi-megawatt classes.

WEC	Rated power	Rotor diameter	Swept area	Hub height	Rotational speed	Cut-out wind speed	Wind zone (DIBt)	Wind class (IEC)
ENERCON E-44	900 kW	44 m	1,521 m ²	45 / 55 m	variable, 16 - 34.5 rpm	28 - 34 m/s	-	IEC/EN IA
ENERCON E-48	800 kW	48 m	1,810 m ²	50 / 60 / 65 / 76 m	variable, 16 - 31.5 rpm	28 - 34 m/s	WZ III	IEC/EN IIA
ENERCON E-53	800 kW	52.9 m	2,198 m ²	50 / 60 / 73 m	variable, 11 - 29.5 rpm	28 - 34 m/s	WZ II exp	IEC/NVN Class S
ENERCON E-70	2,300 kW	71 m	3,959 m ²	57 / 64 / 75 / 85 / 98 / 114 m	variable, 6 - 21 rpm	28 - 34 m/s	WZ III	IEC/EN IA and IEC/EN IIA
ENERCON E-82 E2	2,000 kW	82 m	5,281 m ²	78 / 84 / 85 / 98 / 108 / 138 m	variable, 6 - 18 rpm	28 - 34 m/s	WZ III	IEC/EN IIA
ENERCON E-82 E2	2,300 kW	82 m	5,281 m ²	78 / 84 / 85 / 98 / 108 / 138 m	variable, 6 - 18 rpm	28 - 34 m/s	WZ III	IEC/EN IIA
ENERCON E-82 E4	2,350 kW	82 m	5,281 m ²	59 / 69 / 78 / 84 m	variable, 6 - 18 rpm	28 - 34 m/s	-	IEC/EN IA and IEC/EN IIA
ENERCON E-82 E4	3,000 kW	82 m	5,281 m ²	69 / 78 / 84 m	variable, 6 - 18 rpm	28 - 34 m/s	-	IEC/EN IA and IEC/EN IIA
ENERCON E-92	2,350 kW	92 m	6,648 m ²	78 / 84 / 85 / 98 / 104 / 108 / 138 m	variable, 5 - 16 rpm	28 - 34 m/s	WZ III	IEC/EN IIA
ENERCON E-101	3,050 kW	101 m	8,012 m ²	99 / 124 / 135 / 149 m	variable, 4 - 14.5 rpm	28 - 34 m/s	WZ III	IEC/EN IIA
ENERCON E-101 E2	3,500 kW	101 m	8,012 m ²	74 m	variable, 4 - 14.5 rpm	28 - 34 m/s	WZ IV	IEC/EN IA
ENERCON E-115	3,000 kW	115.7 m	10,515.5 m ²	92 / 122 / 135 / 149 m	variable, 4 - 12.8 rpm	28 - 34 m/s	WZ III	IEC/EN IIA
ENERCON E-126 EP4	4,200 kW	127 m	12,668 m ²	135 m	variable, 3 - 11.6 rpm	28 - 34 m/s	WZ III	IEC/EN IIA
ENERCON E-126	7,580 kW	127 m	12,668 m ²	135 m	variable, 5 - 12.1 rpm	28 - 34 m/s	WZ III	IEC/EN IA



ENERCON power curves

According to current standards, power curve measurement parameters such as turbulence intensity are not taken into consideration. The results are deviating measurements on the same type of wind turbine at different locations. Again, when comparing yield using power curve measurements from different types of wind turbines, a clear picture cannot be obtained unless all measurement parameters are taken into consideration.

So in order to calculate power yield forecasts for its wind turbines, ENERCON does not use power curve measurements but rather calculated power curves.

These are based on the following:

- Experience gained from numerous power curve measurements on various wind turbine types taken by accredited institutes
- Average turbulence intensity of 12%
- Standard air density of 1,225 kg/m³
- Anemometer specifications according to IEC 61400-12-1

Thus, the power curves for ENERCON wind turbines provide highly reliable and realistic calculations for expected energy yield based on the wind conditions at the respective site.

ENERCON storm control

ENERCON wind energy converters run with a special storm control feature. This slows the wind turbine down so that it can continue to operate even at high wind speeds. Numerous shutdowns which lead to considerable losses in power output can thus be avoided.

When storm control is activated, the rated speed is linearly reduced starting at a predetermined wind speed for each turbine type. Beginning at another turbine-specific wind speed, the limitation of the turbine's rated speed also reduces active power. The turbine only shuts down at a wind speed of more than 34 m/s (10-minute average).

In comparison: when storm control is deactivated, the wind turbine stops if the wind speed reaches a 3-minute average of 25 m/s or a 15-second average of 30 m/s.

Power curve without ENERCON storm control

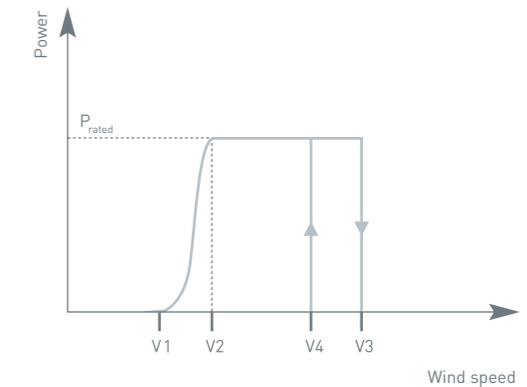

Wind turbine shuts down at preset maximum wind speed (V3).

- V1 = Cut-in wind speed
- V2 = Rated wind speed
- V4 = Cut-in wind speed after deactivated storm control
- V3 = Cut-out wind speed with deactivated storm control

Power curve with ENERCON storm control

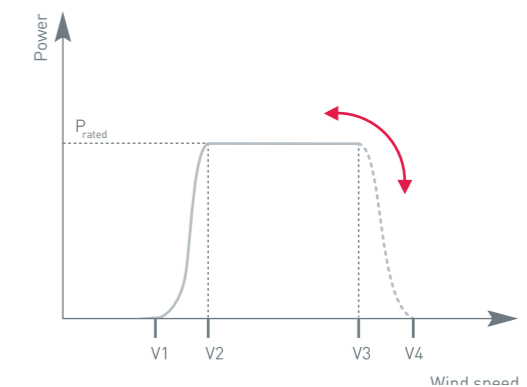

Wind turbine reduces output starting at a determined wind speed (V3). A shutdown does not occur until a predetermined maximum wind speed (V4) is reached.

- V1 = Cut-in wind speed
- V2 = Rated wind speed
- V3 = Beginning of power reduction
- V4 = Cut-out wind speed with activated storm control



Trademark note

ENERCON, Energy for the world, the ENERCON logo and the green tower shades are registered trademarks of ENERCON GmbH.

ENERCON GmbH
Dreekamp 5 · 26605 Aurich, Germany
Telephone +49 4941 927-0
Fax +49 4941 927-109
www.enercon.de
info@enercon.de

Technical information subject to change.
Last updated: June 2015

